



Lenze

smd frequency inverter

These Instructions

- contain important technical data and describe installation, operation and commissioning of the smd frequency inverter.
- are only valid for smd frequency inverters with software rev 14 (see drive nameplate).
- Please read the Instructions before commissioning.



smd401

Commissioning using the Lenze settings		see
1.	Read the Safety Notes	2
2.	Installation	
3.	Wiring of power and control connections Important: Observe minimum wiring requirements!	4
4.	Power up Display: OFF	
5.	Setpoint selection through potentiometer	
6.	Set terminal 28 to HIGH and terminal E2 to LOW. Response: Motor accelerates to setpoint with CW rotation Display shows output frequency in Hz, e.g. 50.0	
7.	If necessary, optimise settings	5
	Faults during commissioning/operation	8

<p>A 4 x M4 B 1.2 Nm C 10 lb-in</p> <p>D 4 x M6 D 2.8 Nm D 24 lb-in</p>									
smd402									
Type ESMD...	a [mm]	a1 [mm]	b [mm]	b1 [mm]	b2 [mm]	c [mm]	s1 [mm]	s2 [mm]	m [kg]
A	371L4TXA	93	84	146	128	17	100	15	0.6
	751L4TXA	93	84	146	128	17	120	15	0.8
	112L4TXA	93	84	146	128	17	146	15	1.0
B	152L4TXA...222L4TXA	114	105	146	128	17	133	15	1.4
	302L4TXA	114	105	146	128	17	171	15	1.7
C	402L4TXA...552L4TXA	114	105	146	95	17	171	15	1.8
	552L2TXA...752L2TXA	146	137	197	140	17	182	30	3.2
D	752L4TXA...113L4TXA	146	137	197	140	17	182	30	3.2
	113L2TXA...153L2TXA	195	183	248	183	23	203	30	6.4
153L4TXA...223L4TXA	195	183	248	183	23	203	30	6.4	

Safety information

General

Some parts of Lenze controllers (frequency inverters, servo inverters, DC controllers) can be live, moving and rotating. Some surfaces can be hot.

Non-authorized removal of the required cover, inappropriate use, incorrect installation or operation, creates the risk of severe injury to personnel or damage to equipment.

All operations concerning transport, installation, and commissioning as well as maintenance must be carried out by qualified, skilled personnel (IEC 364 and CENELEC HD 384 or DIN VDE 0100 and IEC report 664 or DIN VDE0110 and national regulations for the prevention of accidents must be observed).

According to this basic safety information qualified skilled personnel are persons who are familiar with the installation, assembly, commissioning, and operation of the product and who have the qualifications necessary for their occupation.

Application as directed

Drive controllers are components which are designed for installation in electrical systems or machinery. They are not to be used as appliances. They are intended exclusively for professional and commercial purposes according to EN61000-3-2. The documentation includes information on compliance with the EN 61000-3-2.

When installing the drive controllers in machines, commissioning (i.e. the starting of operation as directed) is prohibited until it is proven that the machine complies with the regulations of the EC Directive 98/37/EC (Machinery Directive); EN 60204 must be observed.

Commissioning (i.e. starting of operation as directed) is only allowed when there is compliance with the EMC Directive (89/336/EEC). The drive controllers meet the requirements of the Low Voltage Directive 73/23/EEC. The harmonised standards of the series EN 50178/ DIN VDE 0160 apply to the controllers.

Warning: The availability of controllers is restricted according to EN61800-3. These products can cause radio interference in residential areas. In this case, special measures can be necessary.

Installation

Ensure proper handling and avoid excessive mechanical stress. Do not bend any components and do not change any insulation distances during transport or handling. Do not touch any electronic components and contacts.

Controllers contain electrostatically sensitive components, which can easily be damaged by inappropriate handling. Do not damage or destroy any electrical components since this might endanger your health!

Electrical connection

When working on live drive controllers, applicable national regulations for the prevention of accidents (e.g. VBG 4) must be observed. The electrical installation must be carried out according to the appropriate regulations (e.g. cable cross-sections, fuses, PE connection). Additional information can be obtained from the documentation.

The documentation contains information about installation in compliance with EMC (shielding, grounding, filters and cables). These notes must also be observed for CE-marked controllers. The manufacturer of the system or machine is responsible for compliance with the required limit values demanded by EMC legislation.

Operation

Systems including controllers must be equipped with additional monitoring and protection devices according to the corresponding standards (e.g. technical equipment, regulations for prevention of accidents, etc.). You are allowed to adapt the controller to your application as described in the documentation.

After the controller has been disconnected from the supply voltage, live components and power connection must not be touched immediately since capacitors could be charged. Please observe the corresponding notes on the controller.

Do not continuously cycle input power to the controller more than once every three minutes.

Please close all protective covers and doors during operation.

Note for UL approved system with integrated controllers

UL warnings are notes which apply to UL systems. The documentation contains special information about UL.



Warnings!

- Suitable for use on a circuit capable of delivering not more than 5000 rms symmetrical amperes, 240 V maximum (240 V devices) or 500 V maximum (400/500 V devices) resp.
- Use 60/75 °C or 75 °C copper wire only.
- Shall be installed in a pollution degree 2 macro-environment.

Technical data

Type	Power [kW]	Mains		Output Current ⁽³⁾								
		Voltage, frequency	Current [A] ⁽³⁾	I _r		I _{max} for 60 s						
				[A] ⁽¹⁾	[A] ⁽²⁾	[A] ⁽¹⁾	[A] ⁽¹⁾	[A] ⁽²⁾	[A] ⁽²⁾			
ESMD552L2TXA	5.5	3/PE 230/240 V (180 V -0%...264 V +0%) 50/60 Hz (48 Hz -0%...62 Hz +0%)	25	22	20	33		30				
ESMD752L2TXA	7.5		32	28	26	42		39				
ESMD113L2TXA	11		48	42	39	63		58				
ESMD153L2TXA	15		59	54	50	81		75				
			400 V	480 V	400 V	480 V	400 V	480 V	400 V	480 V	400 V	480 V
ESMD371L4TXA	0.37	3/PE 400/480 V (320 V -0%...528 V +0%) 50/60 Hz (48 Hz -0%...62 Hz +0%)	1.6	1.4	1.3	1.1	1.2	1.0	2.0	1.7	1.8	1.5
ESMD751L4TXA	0.75		3.0	2.5	2.5	2.1	2.3	1.9	3.8	3.2	3.5	2.9
ESMD112L4TXA	1.1		4.3	3.6	3.6	3.0	3.3	2.8	5.4	4.5	5.0	4.2
ESMD152L4TXA	1.5		4.8	4.0	4.1	3.4	3.8	3.1	6.2	5.1	5.7	4.7
ESMD222L4TXA	2.2		6.4	5.4	5.8	4.8	5.3	4.4	8.7	7.2	8.0	6.6
ESMD302L4TXA	3.0		8.3	7.0	7.6	6.3	7.0	5.8	11.4	9.5	10.5	8.7
ESMD402L4TXA	4.0		10.6	8.8	9.4	7.8	8.6	7.2	14.1	11.7	12.9	10.8
ESMD552L4TXA	5.5		14.2	12.4	12.6	11.0	11.6	10.1	18.9	16.5	17.4	15.2
ESMD752L4TXA	7.5		18.1	15.8	16.1	14.0	14.8	12.9	24	21	22	19.4
ESMD113L4TXA	11		27	24	24	21	22	19.3	36	32	34	29
ESMD153L4TXA	15		35	31	31	27	29	25	47	41	43	37
ESMD183L4TXA	18.5		44	38	39	34	36	31	59	51	54	47
ESMD223L4TXA	22		52	45	46	40	42	37	69	60	64	55

(1) For rated mains voltage and carrier frequencies 4, 6, 8 kHz

(2) For rated mains voltage and carrier frequency 10 kHz

(3) Maximum current is a function of setting C90 (input voltage selection)

Conformity	CE	Low Voltage Directive (73/23/EEC)
Approvals	UL 508C	Underwriters Laboratories - Power Conversion Equipment
Max. permissible motor cable length⁽¹⁾	shielded:	50 m (low-capacitance)
	unshielded:	100 m
Environmental conditions	Class 3K3 to EN 50178	
Temperature range	Transport	-25 ... +70 °C
	Storage	-20 ... +70 °C
	Operation	0 ... +55 °C (with 2.5 %/°C current derating above +40 °C)
Installation height	0 ... 4000 m a.m.s.l. (with 5 %/1000 m current derating above 1000 m a.m.s.l.)	
Vibration resistance	acceleration resistant up to 0.7 g	
Earth leakage current (EN 50178)	> 3.5 mA to PE	
Enclosure (EN 60529)	IP 20	
Protection measures against	short circuit, earth fault, overvoltage, motor stalling, motor overload	
Operation in public supply networks (Limitation of harmonic currents according to EN 61000-3-2)	Total power connected to the mains	Compliance with the requirements ⁽²⁾
	< 0.5 kW	With mains choke
	0.5 ... 1 kW	With active filter (in preparation)
	> 1 kW	Without additional measures

(1) For compliance with EMC regulations, the permissible cable lengths may change.

(2) The additional measures described only ensure that the controllers meet the requirements of the EN 61000-3-2.

The machine/system manufacturer is responsible for the compliance with the regulations of the machine!

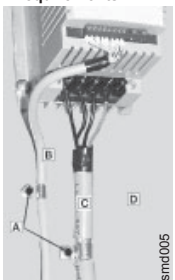
EMC	Compliance with EN 61800-3/A11	Installation according to EMC requirements 
Noise emission	Compliance with limit value class A according to EN 55011 if installed in a control cabinet with the appropriate smd footprint filter and the motor cable length does not exceed 10m	
A Screen clamps		
B Control cable		
C Low-capacitance motor cable (core/core ≤ 75 pF/m, core/screen ≤ 150 pF/m)		
D Electrically conductive mounting plate		

Installation

Connection diagram

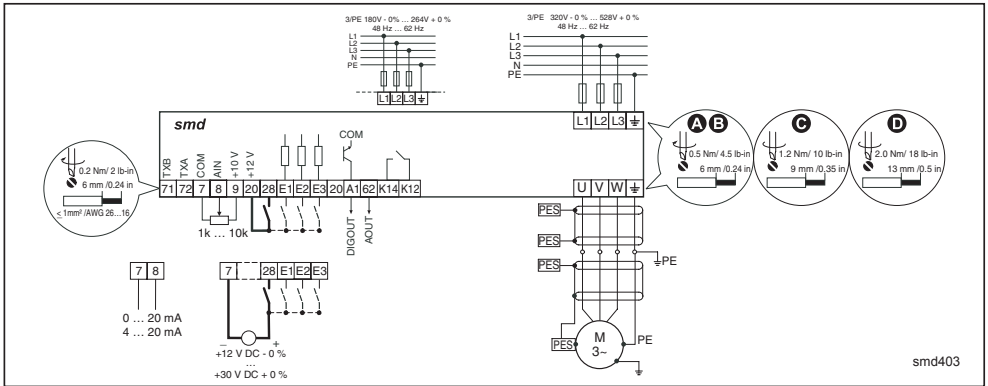

Terminal	Data for control connections (printed in bold = Lenze setting)	
71	RS-485 serial communication input	Modbus or LECOM
72	RS-485 serial communication input	
7	Reference potential	
8	Analog input 0 ... 10 V (changeable under C34)	input resistance: >50 kΩ (with current signal: 250 Ω)
9	Internal DC supply for setpoint potentiometer	+10 V, max. 10 mA
20	Internal DC supply for digital inputs	+12 V, max. 20 mA
28	Digital input Start/Stop	LOW = Stop HIGH = Run Enable
E1	Digital input configurable with CE1 Activate fixed setpoint 1 (JOG1)	HIGH = JOG1 active
E2	Digital input configurable with CE2 Direction of rotation	LOW = CW rotation HIGH = CCW rotation
E3	Digital input configurable with CE3 Activate DC injection brake (DCB)	HIGH = DCB active
A1	Digital output configurable with c17	DC 24 V / 50 mA; NPN
62	Analog output configurable with c08 & c11	
K14	Relay output (normally-open contact)	AC 250 V / 3 A
K12	Fault (TRIP)	DC 24 V / 2 A ... 240 V / 0.22 A

R_i = 3.3 kΩ

Protection against contact

- All terminals have a basic isolation (single insulating distance)
- Protection against contact can only be ensured by additional measures i.e. double insulation

LOW = 0 ... +3 V, HIGH = +12 ... +30 V

Fuses/cable cross-sections⁽¹⁾

Type	Installation to EN 60204-1			Installation to UL		E.I.c.b. ⁽²⁾
	Fuse	Miniature circuit breaker	L1, L2, L3, PE [mm ²]	Fuse ⁽³⁾	L1, L2, L3, PE [AWG]	
ESMD...						≥ 30 mA
371L4TXA...222L4TXA	M10 A	C10 A	1.5	10 A	14	
302L4TXA	M12 A	C12 A	1.5	12 A	14	
402L4TXA	M16 A	C16 A	2.5	15 A	14	
552L4TXA	M20 A	C20 A	2.5	20 A	12	
752L4TXA	M25 A	C25 A	4	25 A	10	
552L2TXA, 113L4TXA	M35 A	C35 A	6	35 A	8	
752L2TXA, 153L4TXA	M45 A	C45 A	10	45 A	8	
183L4TXA	M60 A	C60 A	16	60 A	6	
113L2TXA, 223L4TXA	M70 A	C70 A	16	70 A	6	
153L2TXA	M90 A	C90 A	16	90 A	4	

(1) Observe the applicable local regulations

(2) Pulse-current or universal-current sensitive earth leakage circuit breaker

(3) UL Class CC fast-acting current-limiting type fuses, 200,000 AIC, required. Bussman KTK-R or equivalent

Observe the following when using E.I.c.b.:

- Installation of E.I.c.b. only between supplying mains and controller.
- The E.I.c.b. can be activated by:
 - capacitive leakage currents between the cable screens during operation (especially with long, screened motor cables)
 - connecting several controllers to the mains at the same time
 - RFI filters

Parameter Setting

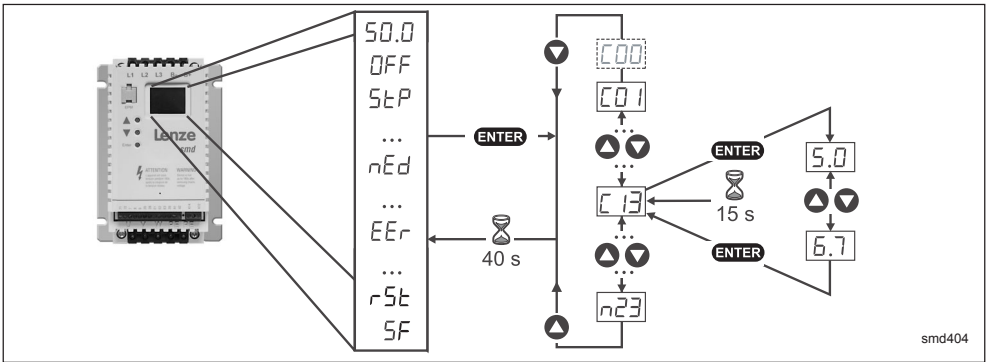



smd404

Code		Possible Settings		IMPORTANT
No.	Name	Lenze	Selection	
C00	Password entry	0	0	999 Visible only when password is active (see C94)
C01	Setpoint and control source	0	0 Analog input (terminal 8) 1 Code c40 2 Analog input (terminal 8) 3 LECOM 4 Analog input (terminal 8) 5 Code c40 6 Analog input (terminal 8) 7 Code c40 8 Analog input (terminal 8) 9 Code c40 10 Analog input (terminal 8) 11 Code c40	Control = terminals Programming = keypad Control = terminals, programming = LECOM/keypad Control = LECOM, programming = LECOM/keypad Control = terminals Programming = remote keypad Control and programming = remote keypad Control = terminals Programming = Modbus/keypad Control = Modbus Programming = Modbus/keypad
C02	Load Lenze setting		0 No action/loading complete 1 Load (only possible with OFF or 1 nh)	Caution: C02 = 1 overwrites all settings
EE1	Configuration - Digital input E1	1	1 Activate fixed setpoint 1 (JOG1) 2 Activate fixed setpoint 2 (JOG2) 3 DC braking (DCB) 4 Direction of rotation	Activate JOG3: Both terminals = HIGH LOW = CW rotation HIGH = CCW rotation
EE2	Configuration - Digital input E2	4	5 Quick stop 6 CW rotation (open-circuit protected) 7 CCW rotation (open-circuit protected)	Controlled deceleration to standstill, active LOW CW rotation = LOW and CCW rotation = LOW: Quick stop
EE3	Configuration - Digital input E3	3	8 UP (setpoint ramp-up) 9 DOWN (setpoint ramp-down) 10 TRIP set 11 TRIP reset	UP = LOW and DOWN = LOW: quick stop; use momentary NC contact Active LOW, triggers EE- NOTE: Thermal NC contact of the motor can be evaluated with this signal see also c70
C08	Configuration - Relay output	1	Relay is energized if 0 Ready 1 Fault 2 Motor is running 3 Motor is running - CW rotation 4 Motor is running - CCW rotation 5 Output frequency = 0 Hz 6 Frequency setpoint reached 7 Threshold (C17) exceeded 8 Current limit (motor or generator mode) reached	
C09	Network address	1	1	247

Parameter Setting

Code		Possible Settings		IMPORTANT	
No.	Name	Lenze	Selection		
C 10	Minimum output frequency	0.0	0.0 {Hz}	240	<ul style="list-style-type: none"> Output frequency at 0% analog setpoint C10 not active for fixed setpoints or setpoint selection via c40
C 11	Maximum output frequency	50.0	7.5 {Hz}	240	<ul style="list-style-type: none"> Output frequency at 100% analog setpoint C11 is never exceeded
C 12	Acceleration time	5.0	0.0 {s}	999	Frequency change 0 Hz ... C11
C 13	Deceleration time	5.0	0.0 {s}	999	Frequency change C11 ... 0 Hz
C 14	Operating Mode	2	0 Linear characteristic with Auto-Boost 1 Square-law characteristic with Auto-Boost 2 Linear characteristic with constant V_{min} boost 3 Square-law characteristic with constant V_{min} boost		<ul style="list-style-type: none"> Linear characteristic: for standard applications Square-law characteristic: for fans and pumps with square-law load characteristic Auto boost: Load-dependent output voltage for low-loss operation
C 15	V/f reference point	50.0	25.0 {Hz}	999	
C 16	V_{min} boost (optimisation of torque behavior)	4.0	0 {%	40	
C 17	Frequency threshold (Q_{min})	0.0	0.0 {Hz}	240	See C08, selection 7 Reference: setpoint 7
C 18	Chopper frequency	2	0 4 kHz 1 6 kHz 2 8 kHz 3 10 kHz (Observe derating, see Technical data)		Automatic derating to 4 kHz at $1.2 \times I_r$
C 21	Slip compensation	0.0	0.0 {%	40.0	Change C21 until the motor speed does not drop any more between no load and maximum load
C 22	Current limit (motor mode)	150	30 {%	150	<ul style="list-style-type: none"> When the limit value is reached either the acceleration time becomes longer or the output frequency becomes lower. If C90 = 2, max setting = 180%
C 24	Accel boost	0.0	0.0 {%	20.0	Accel boost is only active during acceleration
C 34	Configuration - analog input	0	0 0...10 V 1 0...5 V 2 0...20 mA 3 4...20 mA		
C 36	Voltage - DC injection brake (DCB)	4.0	0.0 {%	50.0	
C 37	Fixed setpoint 1 (JOG 1)	20.0	0.0 {Hz}	240	Lenze setting: active at E1 = HIGH
C 38	Fixed setpoint 2 (JOG 2)	30.0	0.0 {Hz}	240	
C 39	Fixed setpoint 3 (JOG 3)	40.0	0.0 {Hz}	240	
C 46	Frequency setpoint		0.0 {Hz}	240	Display: Setpoint via analog input or function UP/DOWN
C 50	Output frequency		0.0 {Hz}	240	Display
C 53	DC bus voltage		0 {%	255	Display
C 54	Motor current		0 {%	255	Display
C 90	Input voltage selection	0	0 Auto 1 Low 2 High		For 200 V or 400 V input For 240 V or 480 V input
C 94	User password	0	0	999	When set to a value other than 0, must enter password at C00 to access parameters
			Changing from "0" (no password), value will start at 763		

Parameter Setting

Code		Possible Settings		IMPORTANT
No.	Name	Lenze	Selection	
c99	Software version			Display, format x.yz
c06	Holding time - automatic DC injection brake (Auto-DCB)	0.0	0.0 {s} 0.0 = not active 999 = continuous brake	999 Automatic motor braking below 0.1 Hz by means of motor DC current for the entire holding time (afterwards: U, V, W inhibited)
c08	Analog output scaling	100.0	0.0	999 When 10 VDC is output at terminal 62, it will equal this value (see c11)
c11	Configuration - analog output (62)	0	0 None 1 Output frequency 0-10 VDC 2 Output frequency 2-10 VDC 3 Load 0-10 VDC 4 Load 2-10 VDC 5 Dynamic Braking	Use c08 to scale signal
c17	Configuration - digital output (A1)	0	Output is energized if 0 Ready 1 Fault 2 Motor is running 3 Motor is running - CW rotation 4 Motor is running - CCW rotation 5 Output frequency = 0 Hz 6 Frequency setpoint reached 7 Threshold (C17) exceeded 8 Current limit (motor or generator mode) reached	
c20	I ² t switch-off (thermal motor monitoring)	100	30 {s} 100% = smd rated output current	100 Caution: Maximum setting is rated motor current (see nameplate) Does not provide full motor protection!
c25	LECOM baud rate	0	0 9600 bps (or 9600,8,N,2 if C01= 8...11) 1 4800 bps (or 9600,8,N,2 if C01= 8...11) 2 2400 bps (or 9600,8,E,1 if C01= 8...11) 3 1200 bps (or 9600,8,O,1 if C01= 8...11)	If C01 = 8...11, Modbus serial communications is active
c40	Frequency setpoint via keys   or Modbus	0.0	0.0 {Hz}	240 Only active if C01 is set properly
c42	Start condition (with mains on)	1	0 Start after LOW-HIGH change at terminal 28 1 Auto start if terminal 28 = HIGH	
c61	Present		status/error message	Display
c62	Last		error message	
c63	Last but one			
c70	Configuration TRIP reset (error reset)	0	0 TRIP reset by LOW - signal at terminal 28 or mains switching or HIGH signal at the digital input "TRIP reset" 1 Auto-TRIP reset	Auto-TRIP reset after the time set in c71
c71	Auto TRIP reset delay	0.0	0.0 {s}	60.0
c78	Operating time counter		Display Total time in status "Start"	0...999 h: format xxx 1000...9999 h: format x.xx (x1000) 10000...99999 h: format xx.x (x1000)
c79	Mains connection time counter		Display Total time of mains = on	
n20	LECOM power up state	0	0 Quick stop 1 Inhibit	
n22	Serial time-out action	0	0 Not active 1 Controller inhibit 2 Quick stop 3 Trip fault "FC3"	Selects controller reaction to serial timeout
n23	Serial fault time	50	50 {ms}	65535 Sets the serial timeout length

Troubleshooting and fault elimination

Status	Cause	Remedy
e.g. SD.0	Present output frequency	Trouble free operation
OFF	Stop (outputs U, V, W inhibited)	LOW signal at terminal 28
INH	Inhibit (outputs U, V, W inhibited)	Controller is set up for serial control (see C01)
StP	Output frequency = 0 Hz (outputs U, V, W inhibited)	Setpoint = 0 Hz
		Quick stop activated through digital input or serial link
LC	Automatic start inhibited	c42 = 0
br	DC-injection brake active	DC-injection brake activated • via digital input • automatically
CL	Current limit reached	Controllable overload
LU	Undervoltage on DC bus	Mains voltage too low
dEL	Overvoltage on DC bus during deceleration (warning)	Excessively short deceleration time
nEd	No access to code	Can only be changed when the the controller is off or inhibited
rC	Remote keypad is active	Attempt to use buttons on front of controller

Error	Cause	Remedy ⁽¹⁾
cF	Data on EPM not valid	Data not valid for controller
		Data error
F I	EPM error	EPM missing or defective
CFG	Digital inputs not unambiguously assigned	E1...E3 assigned with the same digital
		Either just "UP" or "DOWN" used
dF	Dynamic braking fault	Dynamic braking resistors are overheating
EEr	External error	Digital input "TRIP set" is active
F2...FD	Internal fault	
FL3	Communication error	Serial timer has timed out
FL5	Communication error	Serial communication failure
JF	Remote keypad fault	Remote keypad disconnected
DC I	Short-circuit or overload	Short-circuit
		Excessive capacitive charging current of the motor cable
		Acceleration time (C12) too short
		Defective motor cable
		Internal fault in motor
		Frequent and long overload
DC2	Earth fault	Grounded motor phase
		Excessive capacitive charging current of the motor cable
DC6	Motor overload (I ^{2t} overload)	Motor is thermally overloaded, for instance, because of: • impermissible continuous current • frequent or too long acceleration processes
DH	Controller overtemperature	Controller too hot inside
DU	Overvoltage on DC bus	Mains voltage too high
		Excessively short deceleration time or motor in generator mode
		Earth leakage on the motor side
rSt	Faulty auto-TRIP reset	More than 8 errors in 10 minutes
5F	Single phase fault	A mains phase has been lost

(1) The drive can only be restarted if the error message has been reset; see c70